

DKDC - DIALOCK[®] 2-WAY DIAPHRAGM VALVE

DIALOCK[®] diaphragm valve with male ends for solvent welding, metric series

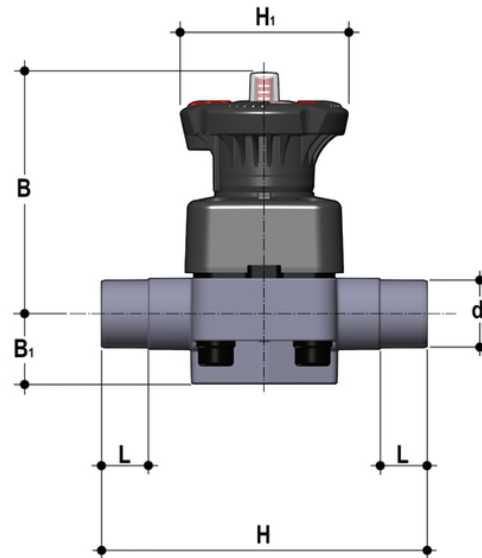

EPDM

Objednací číslo

DKDC020E

DKDC025E

DKDC032E

DKDC040E

DKDC050E

DKDC063E

DKDC075E

FKM

Objednací číslo

DKDC020F

DKDC025F

DKDC032F

DKDC040F

DKDC050F

DKDC063F

DKDC075F



DKDC - DIALOCK[®] 2-WAY DIAPHRAGM VALVE

PTFE

Objednací číslo

DKDC020P

DKDC025P

DKDC032P

DKDC040P

DKDC050P

DKDC063P

DKDC075P

DKDC - DIALOCK® 2-WAY DIAPHRAGM VALVE

The DK DIALOCK® diaphragm valve is particularly suitable for shutting off and regulating abrasive or dirty fluids. The new internal geometry of the body increases flow coefficient, reduce pressure drop and allows a sensitive and precise adjustment along the entire stroke of the shutter. The DK is extremely compact and very light. The innovative handwheel is equipped with a patented immediate and ergonomic operating locking device that allows it to be adjusted and locked in any position.

- **High visibility graduated optical position indicator** protected by a transparent cap with seal O-Ring
- **Customisation plate:** the customisation lets you identify the valve on the system according to specific needs
- **DIALOCK® SYSTEM:** innovative handwheel with a patented immediate and ergonomic operating locking device that allows it **to be adjusted and locked in over 300 positions**
- **Handwheel and bonnet in** high mechanical strength and chemically resistant **PP-GR**, providing full protection by isolating all internal metal parts from contact with external agents
- **Floating pin connection** between the control screw and diaphragm to prevent concentrated loads, improve the seal and extend its lifetime
- **New design of valve body interior: substantially increased flow coefficient** and reduced pressure drop. The degree of efficiency reached has also **enabled the size and weight of the valve to be reduced**
- **Adjustment linearity:** the internal profiles of the valve also greatly improve its characteristic curve, resulting in **extremely sensitive and precise adjustment** along the entire stroke of the shutter
- **Valve anchoring** bracket **integrated in the body**, with threaded metal inserts allowing **simple panel or wall mounting** using the PMDK mounting plate (supplied as an accessory)
- Connection system for solvent weld, threaded and flanged joints
- **Optimised fluid dynamic design:** maximum output flow rate thanks to the optimised efficiency of the fluid dynamics that characterise the new internal geometry of the body
- **Internal components in metal, totally isolated from the fluid** and external environment
- **Modularity of the range:** only 2 handwheel and 4 diaphragm and bonnet sizes for 7 different valve sizes
- Non-rising handwheel that stays at the same height during rotation, equipped with a graduated optical indicator protected by a transparent PVC cap with seal O-Ring
- Bonnet fastening screws in stainless steel protected against the external environment by PE plugs. Absence of metal parts exposed to the external environment to prevent any risk of corrosion.
- **CDSA** (Circular Diaphragm Sealing Angle) system that, thanks to the uniform distribution of shutter pressure on the diaphragm seal, offers the following advantages:
 - reduction in the tightening torque of the screws fixing the actuator to the valve body
 - reduced mechanical stress on all valve components (actuator, body and diaphragm)
 - easy to clean valve interior
 - low risk of the accumulation of deposits, contamination or damage to the diaphragm due to crystallisation
 - operating torque reduction